

**PRELIMINARY**

**PM75RLB060**

FLAT-BASE TYPE  
INSULATED PACKAGE

Notice : This is not a final specification. Some parametric limits are subject to change.

PM75RLB060

Pre.	T.Marumo	Rev.	A
Apr.	M.Yamamoto July.26.2002		<i>M. Tabata 12-Dec-'02</i>

**Feature**

- a) Adopting new 5th generation IGBT(CSTBT) chip, which performance is improved by 1 $\mu$ m fine rule process.  
For example, typical  $V_{ce(sat)}=1.5V$  @ $T_j=125^{\circ}C$
  - b) I adopt the over-temperature conservation by  $T_j$  detection of CSTBT chip, and error output is possible from all each conservation upper and lower arm of IPM.
  - c) New small package  
Reduce the package size by 32%, thickness by 22% from S-DASH series.
  - d) Current rating of brake part increased.  
67% for the current rating of inverter part.
- 3 $\phi$  75A, 600V Current-sense IGBT type inverter
  - 50A, 600V Current-sense regenerative brake IGBT
  - Monolithic gate drive & protection logic
  - Detection, protection & status indication circuits for, short-circuit, over-temperature & under-voltage ( P-Fo available from upper arm devices )
  - Acoustic noise-less 5.5kW/7.5kW class inverter application

OUTLINE DRAWING Dimensions in mm

See Page 7

APPLICATION : General purpose inverter, servo drives and other motor controls

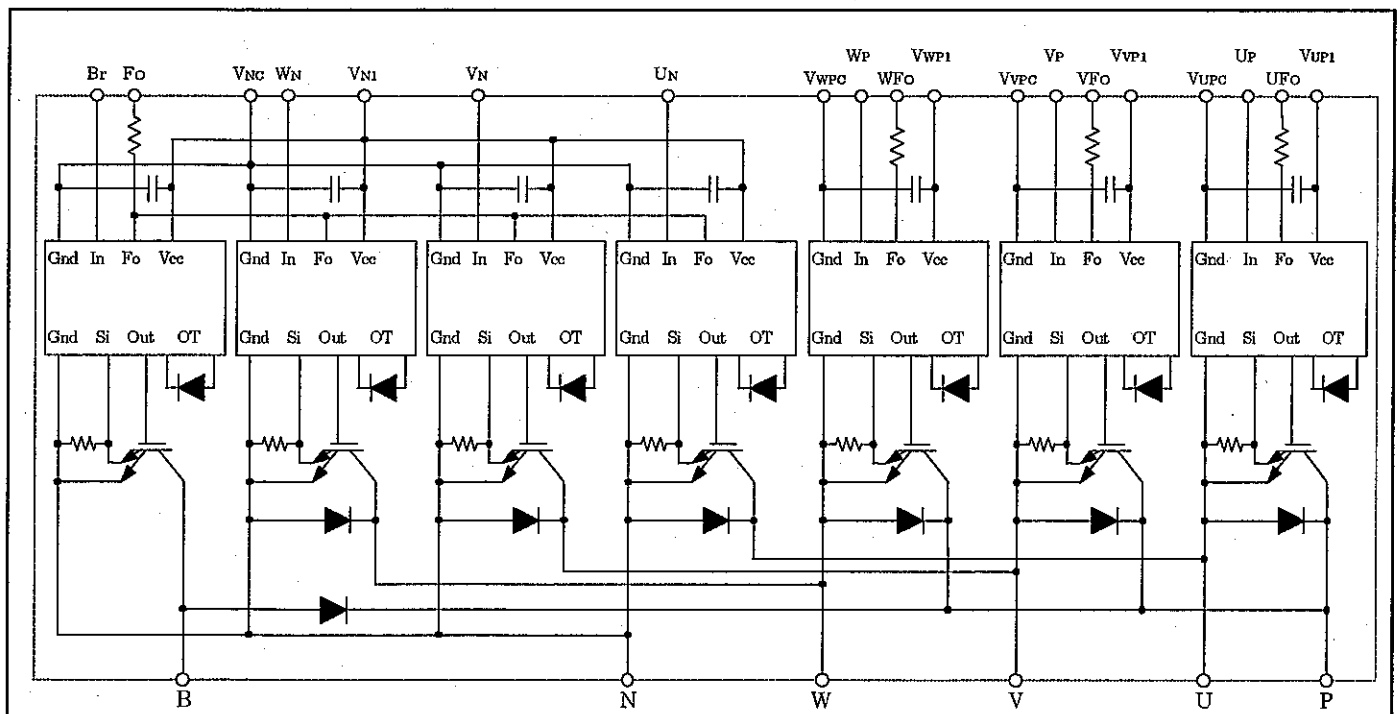

## PM75RLB060

FLAT-BASE TYPE  
INSULATED PACKAGE

Maximum Ratings ( $T_j = 25^\circ\text{C}$ , unless otherwise noted)

### Inverter Part

Item	Symbol	Condition	Ratings	Unit
Collector-Emitter Voltage	$V_{CES}$	$V_D = 15\text{V}, V_{CIN} = 15\text{V}$	600	V
Collector Current	$\pm I_C$	$T_C = 25^\circ\text{C}$	75	A
Collector Current (Peak)	$\pm I_{CP}$	$T_C = 25^\circ\text{C}$	150	A
Collector Dissipation	$P_C$	$T_C = 25^\circ\text{C}$ (Note-1)	297	W
Junction Temperature	$T_j$		-20 ~ +150	$^\circ\text{C}$

### Brake Part

Item	Symbol	Condition	Ratings	Unit
Collector Emitter Voltage	$V_{CES}$	$V_D = 15\text{V}, V_{CIN} = 15\text{V}$	600	V
Collector Current	$I_C$	$T_C = 25^\circ\text{C}$	50	A
Collector Current (Peak)	$I_{CP}$	$T_C = 25^\circ\text{C}$	100	A
Collector Dissipation	$P_C$	$T_C = 25^\circ\text{C}$ (Note-1)	228	W
FWDi Rated DC Reverse Voltage	$V_{R(DC)}$	$T_C = 25^\circ\text{C}$	600	V
FWDi Forward Current	$I_F$	$T_C = 25^\circ\text{C}$	50	A
Junction Temperature	$T_j$		-20 ~ +150	$^\circ\text{C}$

### Control Part

Item	Symbol	Condition	Rating	Unit
Supply Voltage	$V_D$	Applied between : $V_{UP1}-V_{UPC}$ $V_{VP1}-V_{VPC}, V_{WP1}-V_{WPC}, V_{UN1}-V_{UNC}$	20	V
Input Voltage	$V_{CIN}$	Applied between : $U_P-V_{UPC}, V_P-V_{VPC}$ $W_P-V_{WPC}, U_N \cdot V_N \cdot W_N \cdot B_F-V_{NC}$	20	V
Fault Output Supply Voltage	$V_{FO}$	Applied between : $U_{FO}-V_{UPC}, V_{FO}-V_{VPC}$ $W_{FO}-V_{WPC}, F_O-V_{NC}$	20	V
Fault Output Current	$I_{FO}$	Sink current at $U_{FO}, V_{FO}, W_{FO}, F_O$ terminals	20	mA

### Total System

Item	Symbol	Condition	Rating	Unit
Supply Voltage Protected by SC	$V_{CC(prot)}$	$V_D = 13.5 \sim 16.5\text{V}$ Inverter Part, $T_j = +125^\circ\text{C}$ Start	400	V
Supply Voltage (Surge)	$V_{CC(surge)}$	Applied between : P-N, Surge value	550	V
Module Case Operating Temperature	$T_C$	(Note-1)	-20 ~ +100	$^\circ\text{C}$
Storage Temperature	$T_{stg}$		-40 ~ +125	$^\circ\text{C}$
Isolation Voltage	Viso	60Hz, Sinusoidal Charged part to Base, AC 1 min.	2500	Vrms

(Note-1)  $T_C$ (base plate) measurement point is below.

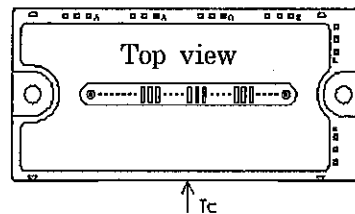

## PM75RLB060

FLAT-BASE TYPE  
INSULATED PACKAGE

### Thermal Resistances

Item	Symbol	Condition	Min.	Typ.	Max.	Unit
Junction to case Thermal Resistances	$R_{th(j-c)Q}$	Inverter IGBT part ( per 1/6 ) (Note-2)	—	—	0.32*	°C/W
	$R_{th(j-c)F}$	Inverter FWDi part ( per 1/6 ) (Note-2)	—	—	0.53*	
	$R_{th(j-c)Q}$	Brake IGBT part (Note-2)	—	—	0.42*	
	$R_{th(j-c)F}$	Brake FWDi part (Note-2)	—	—	0.71*	
	$R_{th(j-c)Q}$	Inverter IGBT part ( per 1/6 ) (Note-1)	—	—	0.42	
	$R_{th(j-c)F}$	Inverter FWDi part ( per 1/6 ) (Note-1)	—	—	0.69	
	$R_{th(j-c)Q}$	Brake IGBT part (Note-1)	—	—	0.55	
	$R_{th(j-c)F}$	Brake FWDi part (Note-1)	—	—	0.92	
Contact Thermal Resistance	$R_{th(c-f)}$	Case to fin, ( per 1 module ) Thermal grease applied (Note-1)	—	—	0.038	

\* If you use this value,  $R_{th(f-a)}$  should be measured just under the chips.

(Note-2)  $T_c$ (under the chip) measurement point is below. (unit : mm)

axis	UP		VP		WP		UN		VN		WN		Br	
	IGBT	FWDi	IGBT	FWDi	IGBT	FWDi	IGBT	FWDi	IGBT	FWDi	IGBT	FWDi	IGBT	FWDi
X	28.7	28.7	65.2	65.2	85.3	85.3	38.0	38.0	55.4	55.4	75.5	75.5	19.0	23.0
Y	-6.6	0.8	-6.6	2.5	-6.6	2.5	4.6	-4.5	4.6	-4.5	4.6	-4.5	-7.3	6.6

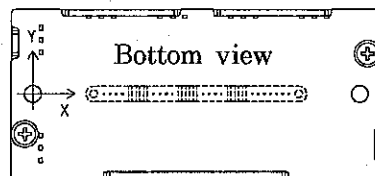

### Electrical Characteristics (T<sub>j</sub> = 25°C unless otherwise noted)

#### Inverter Part

Item	Symbol	Condition	Min.	Typ.	Max.	Unit	
Collector-Emitter Saturation Voltage	$V_{CE(sat)}$	$V_D = 15V, V_{CIN} = 0V$ $I_C = 75A, Pulsed$ Fig.1	T <sub>j</sub> = 25°C	—	1.6	2.1	V
			T <sub>j</sub> = 125°C	—	1.5	2.0	
FWDi Forward Voltage	$V_{EC}$	$I_C = 75A, V_{CIN} = 15V$ $V_D = 15V$ Fig.2	—	2.2	3.3	V	
Switching Time	$t_{on}$	$V_D = 15V, V_{CIN} = 0V \leftrightarrow 15V$ $V_{CC} = 300V, I_C = 75A$ T <sub>j</sub> = 125°C, Inductive Load Fig.3	—	0.5	1.0	μs	
	$t_{rr}$		—	0.2	0.4		
	$t_{c(on)}$		—	0.4	1.0		
	$t_{off}$		—	1.2	2.5		
	$t_{c(off)}$		—	0.5	1.0		
Collector-Emitter Cutoff Current	ICES	$V_{CE} = V_{CES}$ $V_D = 15V$ Fig.4	T <sub>j</sub> = 25°C	—	—	1	mA
			T <sub>j</sub> = 125°C	—	—	10	

#### Brake Part

Item	Symbol	Condition	Min.	Typ.	Max.	Unit	
Collector-Emitter Saturation Voltage	$V_{CE(sat)}$	$V_D = 15V, V_{CIN} = 0V$ $I_C = 50A, Pulsed$ Fig.1	T <sub>j</sub> = 25°C	—	1.6	2.1	V
			T <sub>j</sub> = 125°C	—	1.5	2.0	
FWDi Forward Voltage	$V_{FM}$	$I_F = 50A$ Fig.2	—	2.2	3.3	V	
Collector-Emitter Cutoff Current	ICES	$V_{CE} = V_{CES}$ $V_D = 15V$ Fig.4	T <sub>j</sub> = 25°C	—	—	1	mA
			T <sub>j</sub> = 125°C	—	—	10	

## Control Part

Item	Symbol	Condition	Min.	Typ.	Max.	Unit	
Circuit Current	$I_D$	$V_D = 15V$					
		$V_{CIN} = 15V$	$V_{N1} - V_{NC}$	—	20	30	mA
			$V_{XP1} - V_{XPC}$	—	5	10	
Input ON Threshold Voltage	$V_{th(ON)}$	Applied between : $U_P - V_{UPC}$ , $V_P - V_{VPC}$	1.2	1.5	1.8	V	
Input OFF Threshold Voltage	$V_{th(OFF)}$	$W_P - V_{WPC}$ , $U_N \cdot V_N \cdot W_N \cdot B_F - V_{NC}$	1.7	2.0	2.3		
Short Circuit Trip Level	SC	$-20 \leq T_j \leq 125^\circ C$ $V_D = 15V$ Fig.5,6	Inverter part	150	—	—	A
			Brake part	100	—	—	
Short Circuit Current Delay Time	$t_{off(SC)}$	$V_D = 15V$ Fig.5,6	—	10	—	$\mu s$	
Over Temperature Protection	OT	Detect $T_j$ of IGBT chip	Trip level	135	145	155	$^\circ C$
	OTr		Reset level	—	125	—	
Supply Circuit Under Voltage Protection	UV	$-20 \leq T_j \leq 125^\circ C$	Trip level	11.5	12.0	12.5	V
	UVr		Reset level	—	12.5	—	
Fault Output Current	$I_{FO(H)}$	$V_D = 15V, V_{CIN} = 15V$		—	—	0.01	mA
	$I_{FO(L)}$		(Note-2)	—	10	15	
Minimum Fault Output Pulse Width	$t_{FO}$	$V_D = 15V$ (Note-2)	1.0	1.8	—	ms	

(Note-2) Fault output is given only when the internal SC, OT & UV protections schemes of either upper or lower arm device operate to protect it.

## Mechanical Ratings and characteristics

Item	Symbol	Condition	Min.	Typ.	Max.	Unit
Mounting torque	—	Mounting part screw : M 5	2.5	3.0	3.5	N · m
Weight	—	—	—	340	—	g

## Recommended Conditions For Use

Item	Symbol	Condition	Recommended value	Unit
Supply Voltage	$V_{CC}$	Applied across P-N terminals	$\leq 400$	V
Control Supply Voltage	$V_D$	Applied between : $V_{UP1} - V_{UPC}$ $V_{VP1} - V_{VPC}$ , $V_{WP1} - V_{WPC}$ , $V_{N1} - V_{NC}$ (Note-3)	$15.0 \pm 1.5$	V
Input ON Voltage	$V_{CIN(ON)}$	Applied between : $U_P - V_{UPC}$ , $V_P - V_{VPC}$	$\leq 0.8$	V
Input OFF Voltage	$V_{CIN(OFF)}$	$W_P - V_{WPC}$ , $U_N \cdot V_N \cdot W_N \cdot B_F - V_{NC}$	$\geq 9.0$	
PWM Input Frequency	$f_{PWM}$	Using Application Circuit of Fig.8	$\leq 20$	kHz
Arm Shoot-through Blocking Time	$t_{dead}$	For IPM's each input signals Fig.7	$\geq 2.0$	$\mu s$

(Note-3) With ripple satisfying the following conditions  
 $dv/dt$  swing  $\leq \pm 5V/\mu s$ , Variation  $\leq 2V$  peak to peak

## Precautions for testing

- Before applying any control supply voltage ( $V_D$ ), the input terminals should be pulled up by resistors, etc. to their corresponding supply voltage and each input signal should be kept off state. After this, the specified ON and OFF level setting for each input signal should be done.
- When performing "SC" tests, the turn-off surge voltage spike at the corresponding protection operation should not be allowed to rise above  $V_{CES}$  rating of the device.  
(These test should not be done by using a curve tracer or its equivalent.)

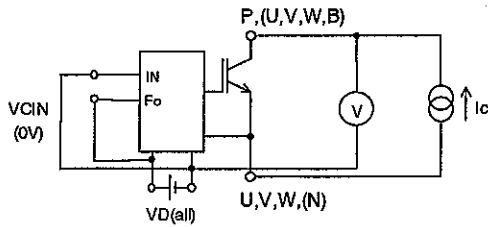

Fig.1  $V_{CE(sat)}$  Tset

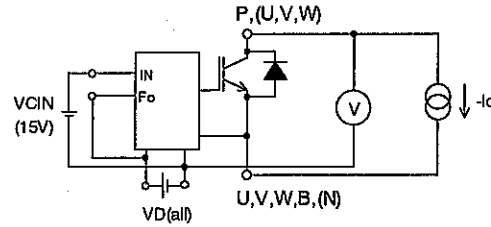

Fig.2  $V_{EC}, (V_{FM})$  Tset

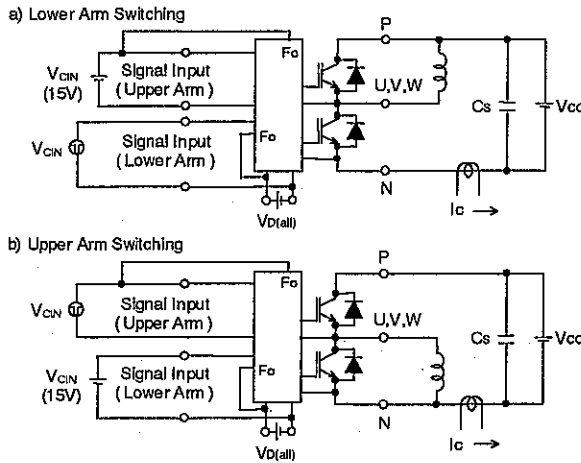

Fig.3 Switching time test circuit and waveform

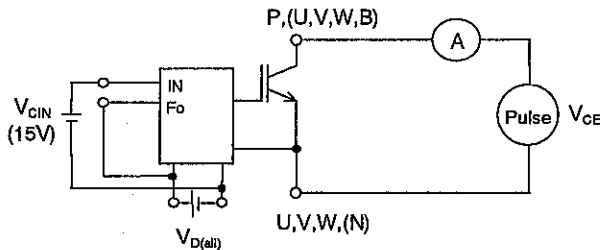

Fig4 ICES Test

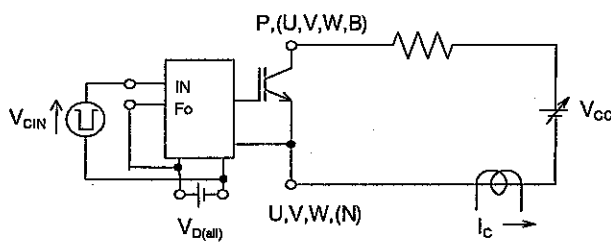

Fig.5 SC Test

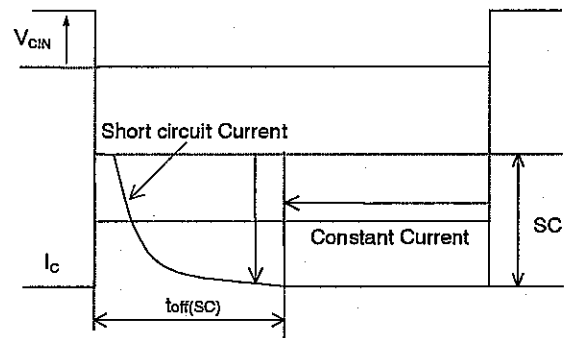
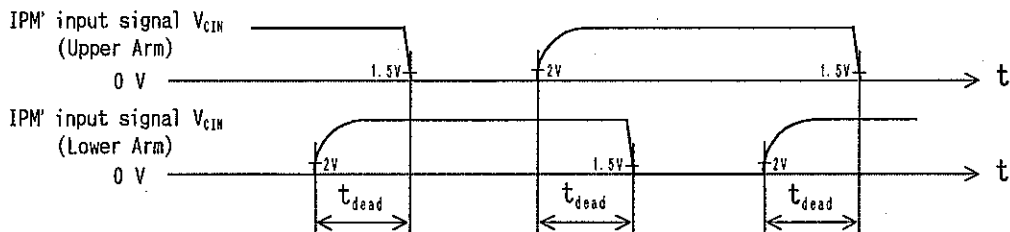
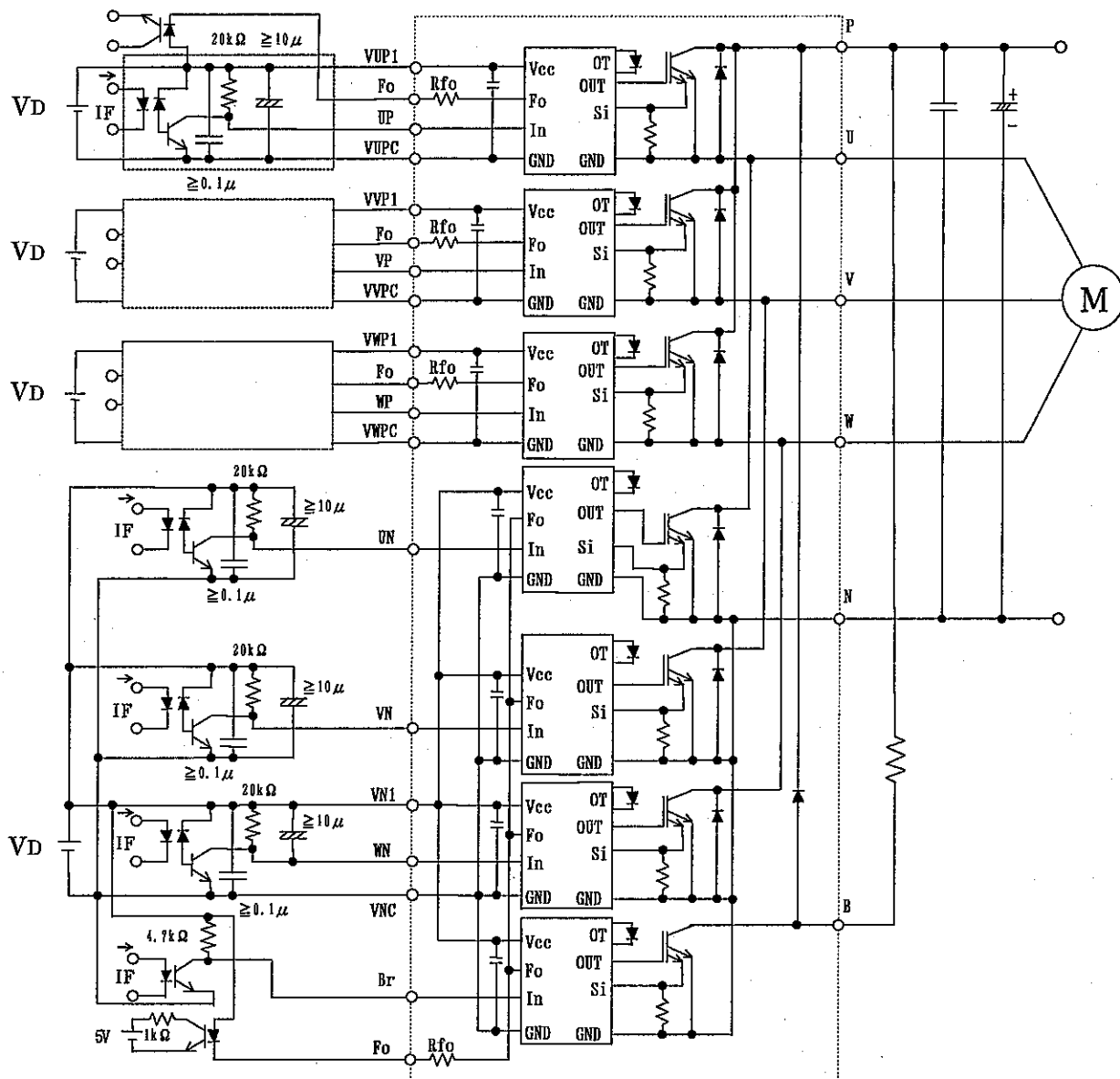

Fig.6 SC Test waveform



1.5V: Input on threshold voltage  $V_{th(on)}$  typical value, 2V: Input off threshold voltage  $V_{th(off)}$  typical value

Fig.7 Dead time measurement point example



: Interface which is the same as the U-phase

Fig. 8 Application Example Circuit

Notes for stable and safe operation ;

- Design the PCB pattern to minimize wiring length between opto-coupler and IPM's input terminal, and also to minimize the stray capacity between the input and output wirings of opto-coupler.
- Connect low impedance capacitor between the Vcc and GND terminal of each fast switching opto-coupler.
- Fast switching opto-couplers :  $t_{PLH}, t_{PHL} \leq 0.8 \mu s$ , Use High CMR type.
- Slow switching opto-coupler :  $CTR > 100\%$
- Use 4 isolated control power supplies ( $V_D$ ). Also, care should be taken to minimize the instantaneous voltage charge of the power supply.
- Make inductance of DC bus line as small as possible, and minimize surge voltage using snubber capacitor between P and N terminal.
- Use line noise filter capacitor ( ex.  $4.7nF$  ) between each input AC line and ground to reject common-mode noise from AC line and improve noise immunity of the system.

Outline drawings

[Dimensions in mm]

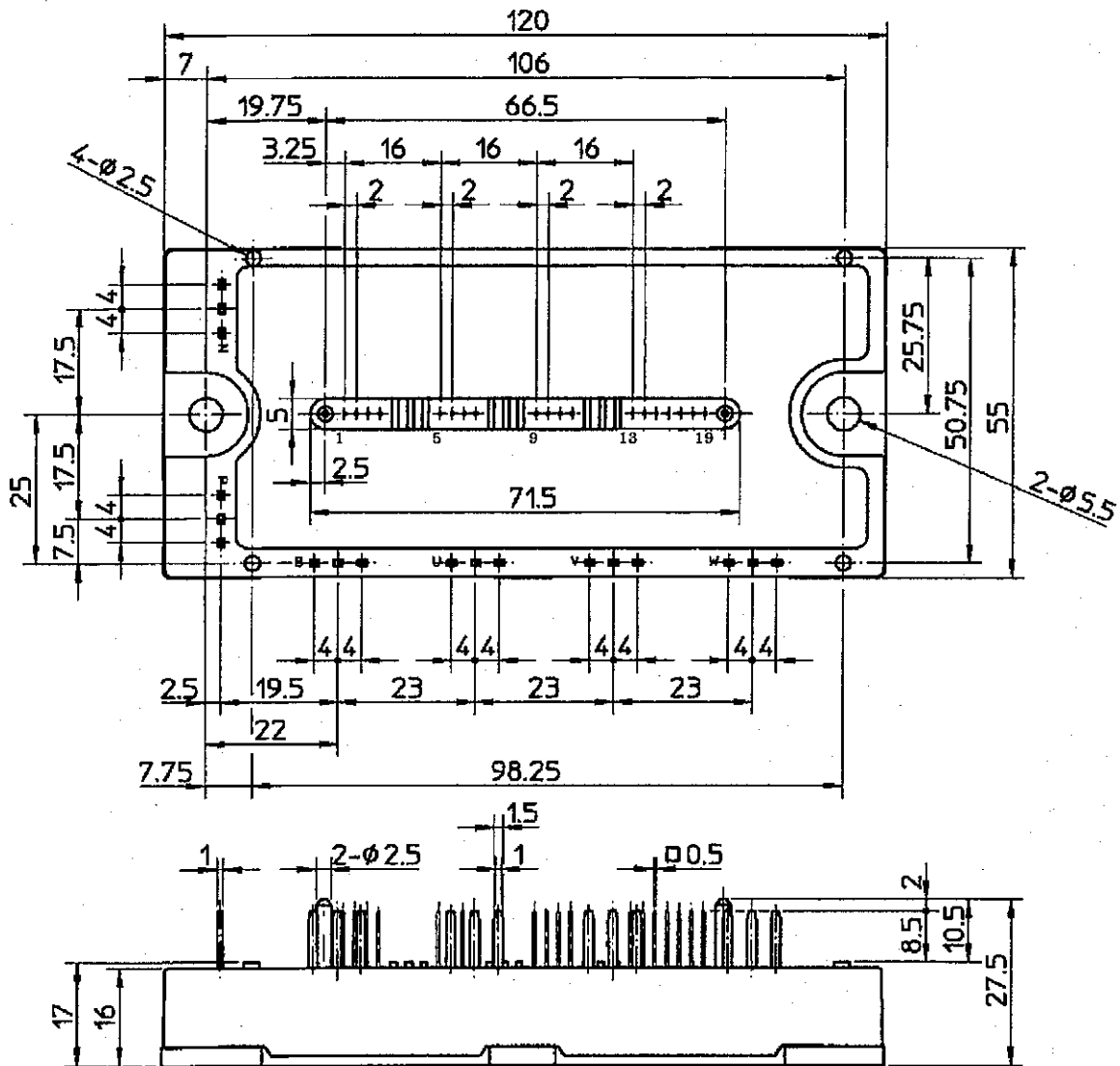

Terminal code

1. VUPC	6. VFO	11. WP	16. UN
2. UFO	7. VP	12. VWP1	17. VN
3. UP	8. VVP1	13. VNC	18. WN
4. VUP1	9. VWPC	14. VN1	19. Fo
5. VVPC	10. WFO	15. Br	